



Guide



# TJEP QUICK-FAST®



# TJEP QUICK-FAST®

F/TJEP PQZ-64



- DK:** Afmonter skruve + næse.  
**UK:** Remove screw + nose.  
**DE:** Schraube + Nase abmontieren.  
**FR:** Retirer la vis + le nez.



- DK:** Monter ny næse.  
**UK:** Insert new nose.  
**DE:** Neue Nase montieren.  
**FR:** Insérer le nouveau nez.



- DK:** Monter TJEP QUICK-FAST®.  
**UK:** Mount TJEP QUICK-FAST®.  
**DE:** TJEP QUICK-FAST® montieren.  
**FR:** Monture TJEP QUICK-FAST®.

**DK:** Ved afstande på under 6 mm **skal** næsestykke/driver guide udskiftes.

**UK:** At distances of less than 6 mm, the driver guide **must** be replaced.

**DE:** Bei Abständen von weniger als 6 mm **muss** die Schlagstiftführung ersetzt werden.

**FR:** Pour les distances inférieures à 6 mm le driver **doit** être changé.



- DK:** Afmonter rørsplit med dorn.  
**UK:** Remove split pin with a mandrel.  
**DE:** Rohrstift durch austreiben mit Durchschlag entfernen.  
**FR:** Démontez le conduit à l'aide d'un tuteur.



- DK:** Udskift næsestykke/driver guide.  
**UK:** Replace driver guide.  
**DE:** Schlagstiftführung ersetzen.  
**FR:** Changez le driver.



- DK:** Monter rørsplit igen.  
**UK:** Refit split pin.  
**DE:** Rohrstift wieder montieren.  
**FR:** Montez le conduit à nouveau.



# IMPORTANT

**SOFTWOOD**

Q MAX 700 kg/m<sup>3</sup>

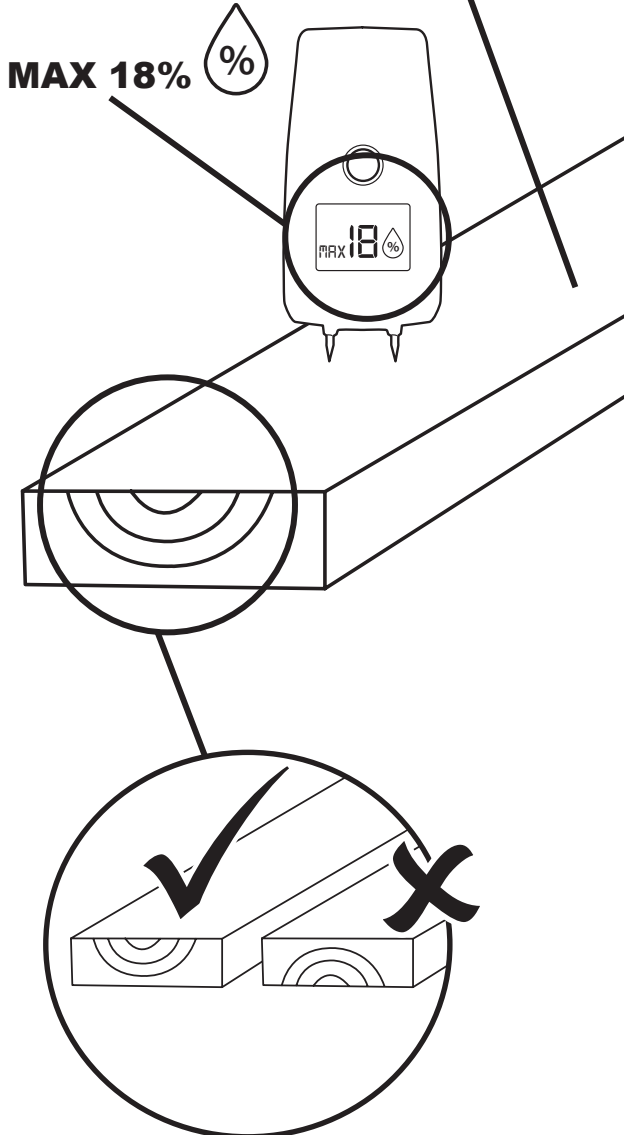

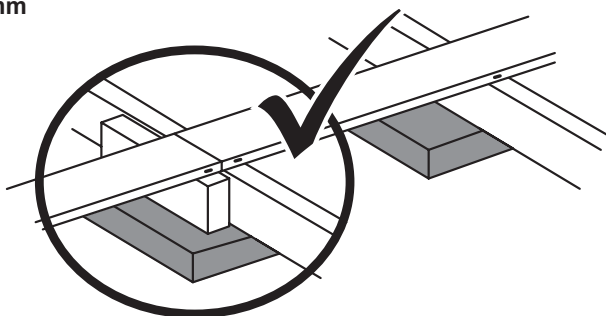
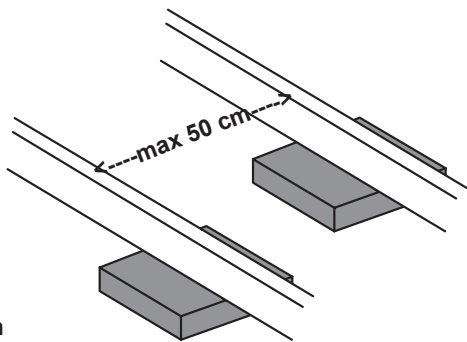
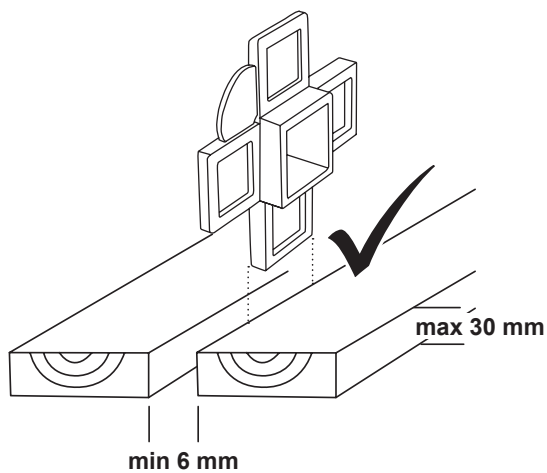

KYOCERA UNIMERCO Fastening A/S

DK-7451 Sunds · Tlf. +45 97 14 14 40 · [tjep@kyocera-unimerco.com](mailto:tjep@kyocera-unimerco.com) · [www.tjep.eu](http://www.tjep.eu)