

## 7 T SPLITTER

With a splitting force of 7 tonnes, the scheppach HL760LS horizontal log splitter splits firewood with lengths of up to 52 cm into fire-sized logs. Two-handed operation and a cover in the splitting area provide optimised safety, while the stable splitting blade takes care of the hardest work when splitting wood. The transport wheels make the horizontal splitter easy to transport and mobile.

- Splits up to 100 pieces of wood per hour
- Splits stored and fresh wood effortlessly
- Splitting force: 7 tonnes
- Max. up to 52 cm
- wood length, up to 25 cm diameter
- Hydraulic cylinder with automatic return
- Warp-resistant, powder-coated steel structure
- Stable splitting blade
- Powerful motor of 2200 W
- Freely-adjustable splitting stroke
- Optimised safety thanks to two-handed operation
- Low-maintenance machine that does not require much space
- Safety cover in the splitting area
- Tray table for logs
- Safe and quiet operation
- Including machine stand with transport wheels



Variable stroke adjustment

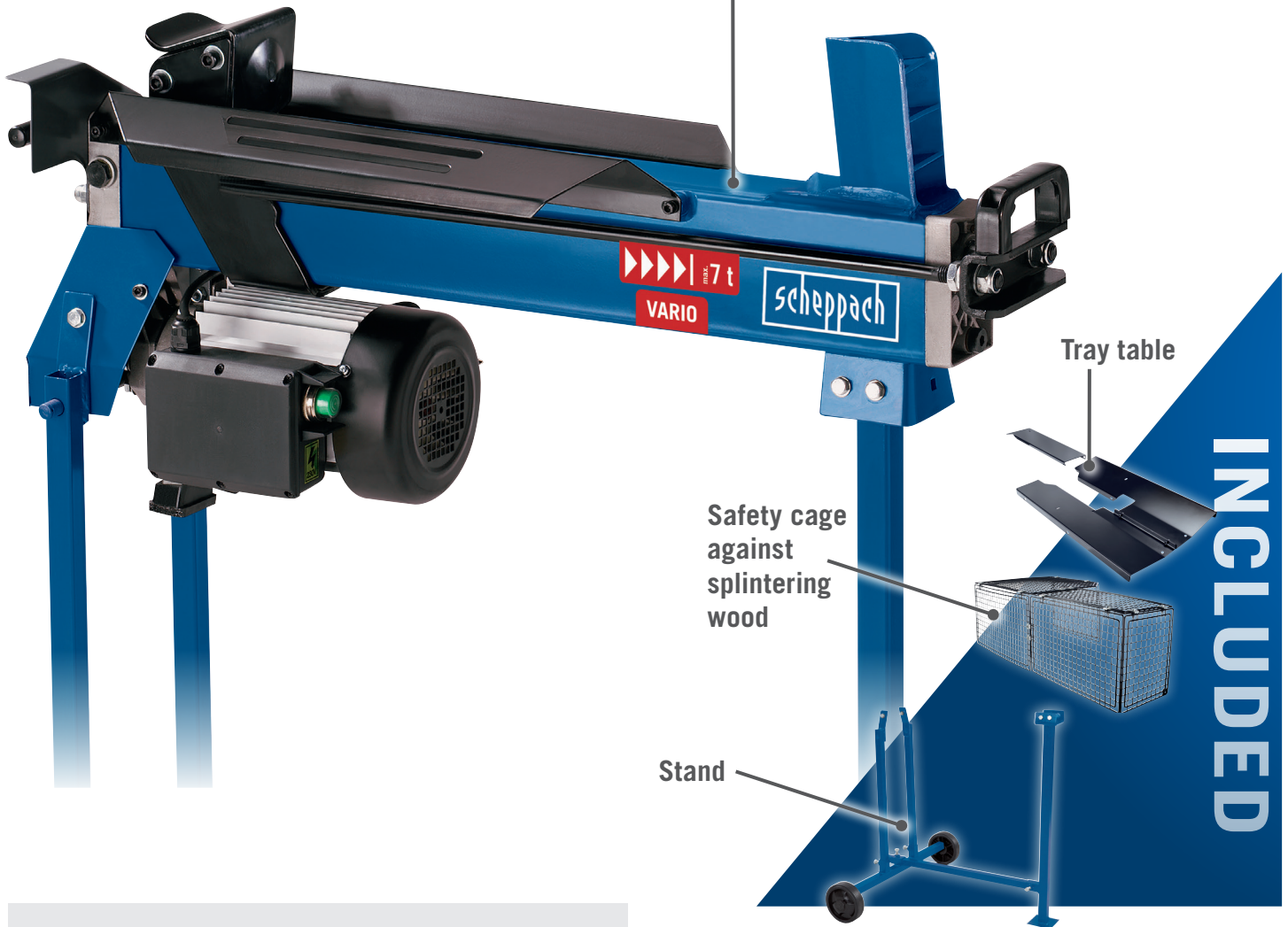

### SPECIFICATIONS

Dimensions L x W x H	1160 x 425 x 610 mm
Splitting power max.	7 t
Wood Ø min. – max.	55 – 250 mm
Wood length max.	520 mm
Speed forward	31mm/s
Speed backward	53mm/s
Motor	220 – 240 V~ / 50 Hz
Input	2200 W

### LOGISTICAL DATA

Weight net / gross	64 / 68,6 kg
Packaging dimensions	950 x 325 x 510 mm
Order number	5905211934
Barcode	4046664120698
20 Container	168 pcs
40 Container	352 pcs
40 HQ Container	440 pcs

## 7 T SPLTTER

With a splitting force of 7 tonnes, the scheppach HL760L horizontal log splitter splits firewood with lengths of up to 52 cm into fire-sized logs. Two-handed operation and a cover in the splitting area provide optimised safety, while the stable splitting blade takes care of the hardest work when splitting wood. The transport wheels make the horizontal splitter easy to transport and mobile.

- Splits up to 100 pieces of wood per hour
- Splits stored and fresh wood effortlessly
- Splitting force: 7 tonnes
- Max. up to 52 cm
- wood length, up to 25 cm diameter
- Hydraulic cylinder with automatic return
- Warp-resistant, powder-coated steel structure
- Stable splitting blade
- Powerful motor of 2200 W
- Freely-adjustable splitting stroke
- Optimised safety thanks to two-handed operation
- Low-maintenance machine that does not require much space
- Safety cover in the splitting area
- Tray table for logs
- Safe and quiet operation

### OPTIONAL ACCESSORIES

#### STAND WITH WHEELS

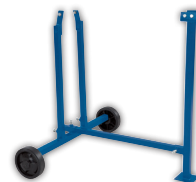

Order No: 7905203701  
Barcode: 4014915228035



Safety cage  
against  
splintering wood



Variable  
stroke  
adjustment

Tray table

Safety cage  
against  
splintering  
wood

INCLUDED



### SPECIFICATIONS

Dimensions L x W x H	1160 x 425 x 610 mm
Splitting power max.	7 t
Wood-Ø min. – max.	55 – 250 mm
Wood length max.	520 mm
Speed forward	31mm/s
Speed backward	3mm/s
Motor	220 – 240 V~ / 50 Hz
Input	2200 W

### LOGISTICAL DATA

Weight net / gross	59 / 63 kg
Packaging dimensions	950 x 325 x 510 mm
Order number	5905211903
Barcode	4046664121787
20 Container	168 pcs
40 Container	344 pcs
40 HQ Container	430 pcs